

# 4-WAY DIVERTER VALVE

M&J VALVE®



M&J Valve was founded in 1962 by Marvin Grove and has been a leader in the pipeline valve industry since its inception. Now part of Celero Flow Technology. The M&J Valve brand meets or exceeds the quality standards of our customers and the valve industry. With a product offering of slab and expanding through-conduit gate valves, axial surge valves and rotary control valves, piston and swing check valves. Celeros can provide a wide variety of flow control solutions for liquid, geothermal and gas markets. This combination of products, technical know-how and field experience has allowed for a history of product innovation which has positioned Celeros in a leadership position within the valve industry.

## A DIVERTER VALVE SYSTEM BY FLOW MEASUREMENT AND VALVE SPECIALISTS

The 4-Way Diverter Valve and its operating mechanism (manual, electric motor or hydraulic actuator) are designed to operate as a system ideally suited for meter proving, which requires:

Frequent operation (cycling). A diverter valve often is cycled 300 times per day compared to once per week for ordinary valves and only twice per year for many valves.

Rapid operation. In bi-directional meter proving the diverter valve must cycle in 4 to 10 seconds compared to the 30 to 60 seconds cycling time for ordinary valves.

No Leakage. Proof of no leakage during each prover run is required by the API Liquid Measurement Manual 2531. The 4-Way Diverter Valve with its automatic pressure seating method indicates the seal condition every time the valve seats. On automated systems, prover runs are canceled if the seal condition is not acceptable.

Figure 1 and 3 show the decrease in body pressure in the seated position as compared to the unseated of cycling position (Fig. 2).

The pressure drops as the valve is being seated because the downward movement of the tapered plug and the compression of the resilient seals create a net volume increase in the body cavity.

This automatic decrease in body pressure is called "SID" or Self Induced Differential.

Low differential sealing. The diverter valve must show sealing proof at low differential pressures (2-5 psi) compared to the high differential pressures (40-400 psi) across normal valve seals. Average (normal) valves require the higher pressures to "set" or "energize" their seats, but this helpful seating force is not available in bi-directional prover systems.

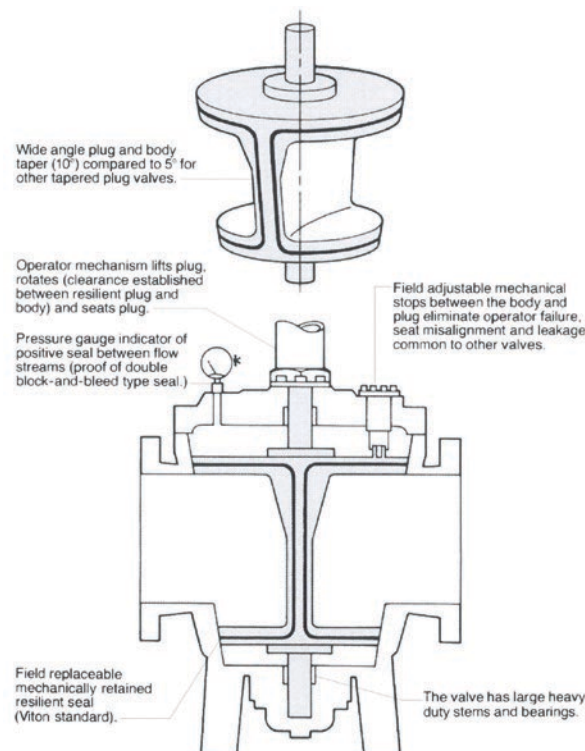

### DIVERTER VALVE CYCLE IN BI-DIRECTIONAL PROVER

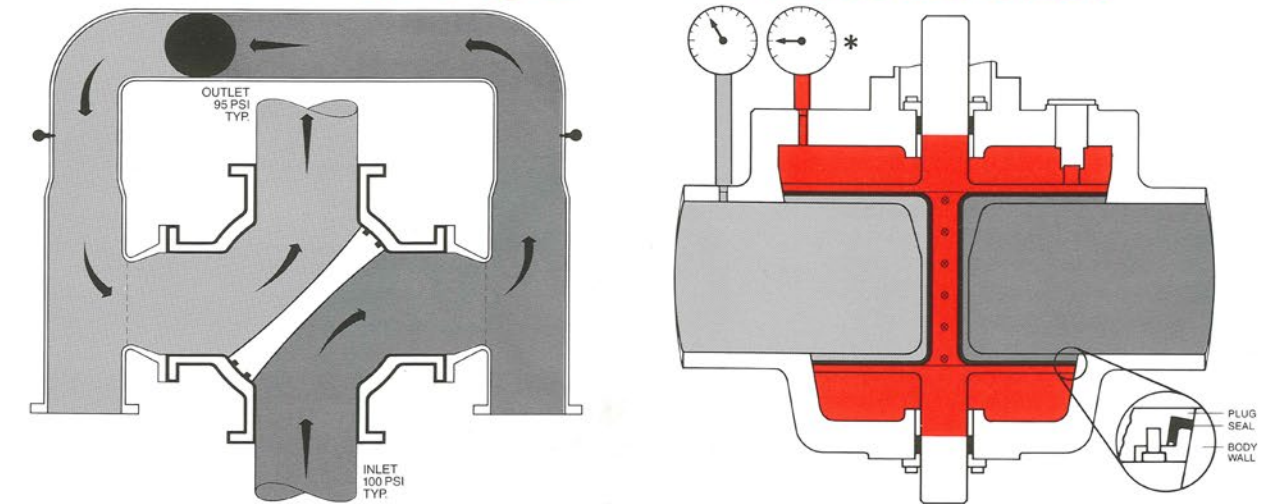

Fig. 1: Valve seated: Pressure gauge automatically indicates reduced body pressure (red area) which proves tight shut-off and positive separation of flow streams.

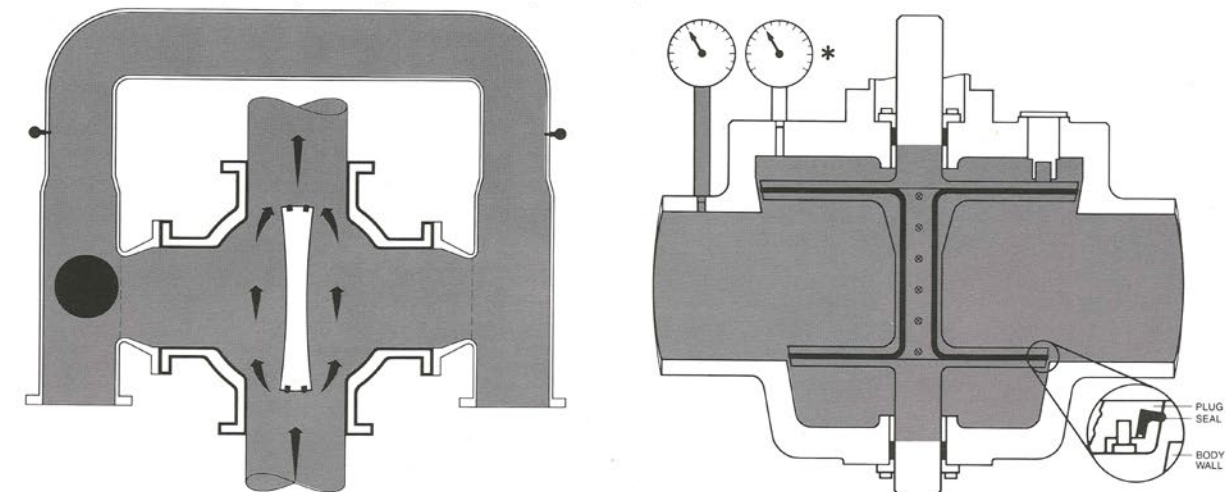

Fig. 2: Valve unseated: Plug is raised to effect clearance between resilient seals and body seats. Plug turns and halfway through cycle flow passes directly through valve (from inlet to outlet port) with very little restriction.

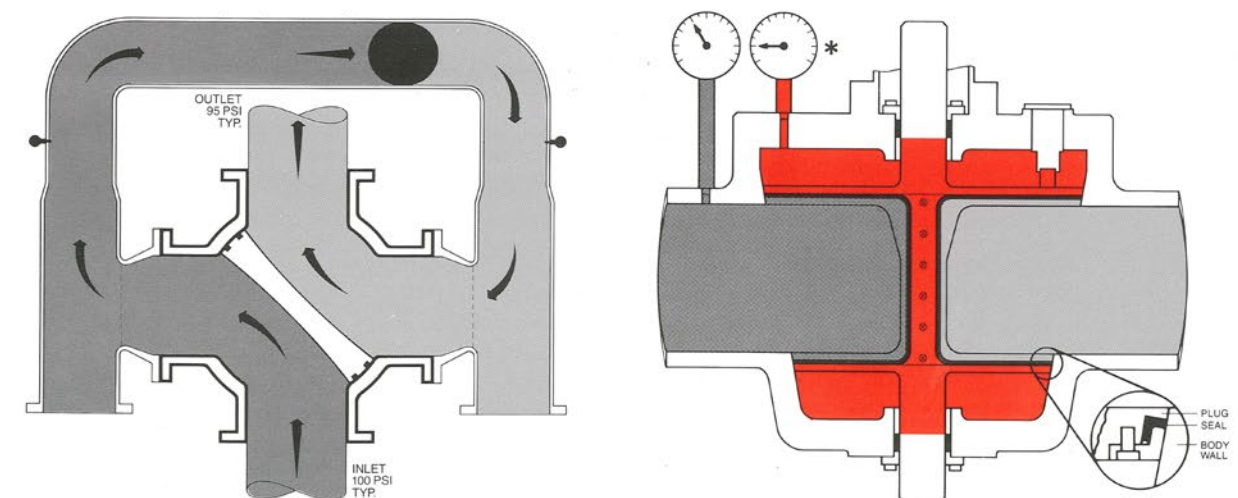

Fig. 3: Valve seated in opposite position: Plug has been lowered seals compressed and reduced body pressure (red areas) again indicates seal integrity, separation of flow streams at low differential pressures.

\* The Pressure gauges shown in Figures 1, 2 and 3 are for illustration only. A differential pressure gauge is provided (standard) with each valve.

## DIVERTER VALVE CYCLE IN BI-DIRECTIONAL PROVER

The widely accepted "Pressure Gauge Seating Method" for proof of "Double Block and Bleed Type Seals" has been simplified with the use of the Differential Pressure Gauge. Our 4-Way valves are supplied with a 0-50 psi differential pressure gauge. The differential check relief valve assembly' is set to hold a 25 psi lower pressure in the body than the prover or valve port. The 25 psi differential is indicated on the 0-50 psi differential pressure gauge which is easy to read. The Differential Pressure Gauge Seating Method is simple, automatic, without solenoids, etc.; and a differential pressure switch for remote indication can be easily installed.

### Low Pressure Loss

Sizes	3"	4"	6"	8"	10"	12"	16"	20"	24"
Cv Values	400	647	1550	2425	4250	5100	8800	14000	19000

### Face to Face Dimensions

Sizes	3"	4"	6"	8"	10"	12"	16"	20"	24"
ANSI 300	17"	17"	24"	24"	32"	32"	48"	58"	58"
ANSI 600	18"	18"	26"	26"	36"	36"	48"	62"	62"
ANSI 900	11.75"	13.50"	-	-	-	-	-	-	-

**M&J VALVE®**

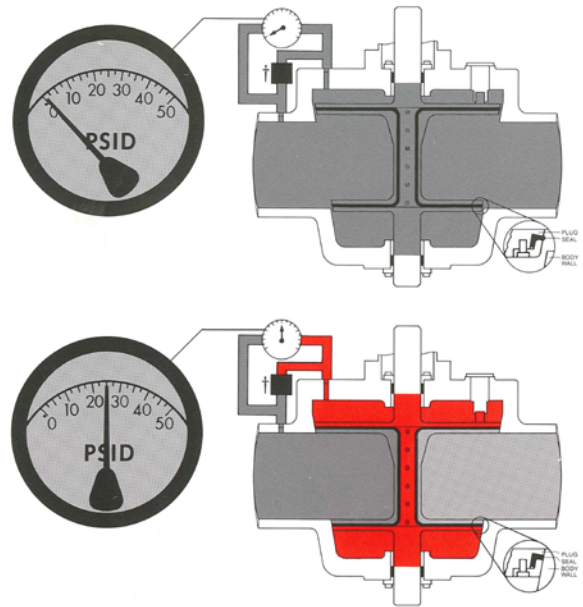

#### AMERICAS

Houston, USA

P: +1 800 231 3690 or +1 281 469 0550

E: [mj.valve@celerosft.com](mailto:mj.valve@celerosft.com)

Jenks, OK, USA

P: +1 918 701 2660

E: [mj.valve@celerosft.com](mailto:mj.valve@celerosft.com)

#### ASIA

Shanghai, China

E: [mj.valve@celerosft.com](mailto:mj.valve@celerosft.com)

#### MIDDLE EAST

Abu Dhabi, UAE

P: +971 2 408 1900

E: [mj.valve@celerosft.com](mailto:mj.valve@celerosft.com)

Dubai, UAE

P: +971 4 5289 555

E: [mj.valve@celerosft.com](mailto:mj.valve@celerosft.com)

*Celeros Flow Technology reserves the right to incorporate our latest design and material changes without notice or obligations. Design features, materials of construction and dimensional data, as described in this bulletin, are provided for your information only and should not be relied upon unless confirmed in writing. Please contact your local sales representative for product availability in your region. For more information visit [www.celerosft.com](http://www.celerosft.com).*

MJ\_4 Way Diverter Valve\_610\_US\_05/2024

[www.celerosft.com](http://www.celerosft.com)

COPYRIGHT © 2024 Celeros Flow Technology, LLC