

Kinetrol Manual Fail-Safe Spring Units

If you want to operate a valve manually, but maintain the advantage of the fail-safe spring's certainty of position when unattended, use this device.

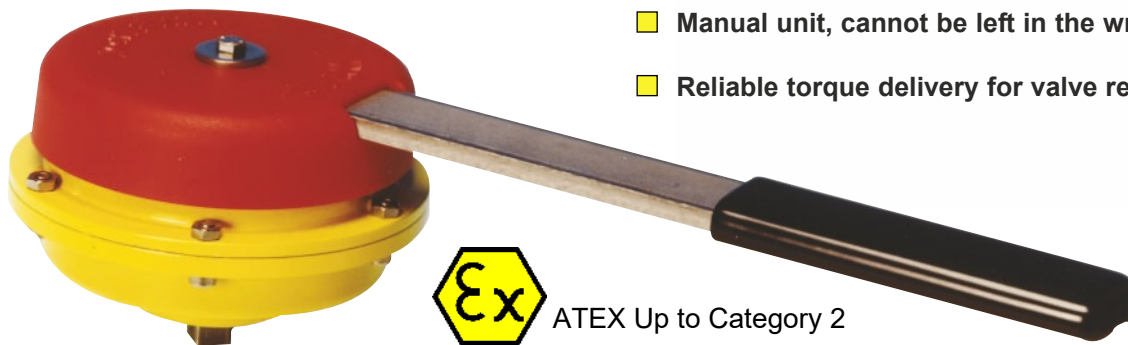

- Manual unit, cannot be left in the wrong position
- Reliable torque delivery for valve reset



ATEX Up to Category 2

- ISO5211 female drive & ATEX Category 2 approved options available for models 02, 03, 05 and 07
- Clockwise or counter clockwise 90° spring action
- Spring housing sealed to IP65 to protect from internal corrosion
- Bi-square (star) and serrated female drive options available

Application

Manual fail-safe spring units are available in Kinetrol sizes 02, 03, 05 and 07 with factory adjusted torques from 1.4Nm to 45.5Nm.

Direction of Spring Action

Manual fail safe spring units are available for either clockwise or counter clockwise spring action and the direction of the unit is determined by looking from above with the mounting interface on the bottom.

Suffix - 020 = clockwise
 Suffix - 030 = counter clockwise

Ordering Codes

To order a manual fail-safe spring unit, quote model number, direction of spring followed by product type code:

Type Codes: -1006 Manual spring unit (e.g. 054-020-1006)
 -1016 ATEX manual spring unit

For reduced torque versions contact Kinetrol.

Specification

Spring Case	02, 03, 05 & 07 ATEX	Die cast zinc alloy, epoxy paint finish
	07 non-ATEX	Die cast aluminium alloy, epoxy paint finish
Shaft		Stainless steel or carbon steel zinc plated
Manual lever		03, 05 & 07 - Stainless Steel 02 - Aluminium
Working Temperature range		-40°C to +80°C (-40°F to +176°F)

ISO/Female Drive Versions

The 03, 05 and 07 models are available with female drives for direct mount. The model 03 has F03/F05 or F04 mounting flanges, the model 05 has F03/F05/F07 or F04 flanges and the model 07 has a F05/F07 flange.

To order female drive versions, replace the '0-' in the product code with '3F'. For example a model 05 ISO female drive manual fail-safe cw handle with F03/F05/F07 flanges is coded: 053F020-1006. The F04 flange version is coded 053F020-1006/F4.

Female drive versions with the same flange dimensions are available with ANSI threads eg 057F020-1006/F4. Serrated female drive options can also be supplied for models 05 and 07. To order these replace the 'F' in the product code with an 'S'. Female 02 versions are available by use of an ISO adaptor, see ISO Adaptor data sheet.

Kinetrol Manual Fail-Safe Spring Units

Dimensions/Torques

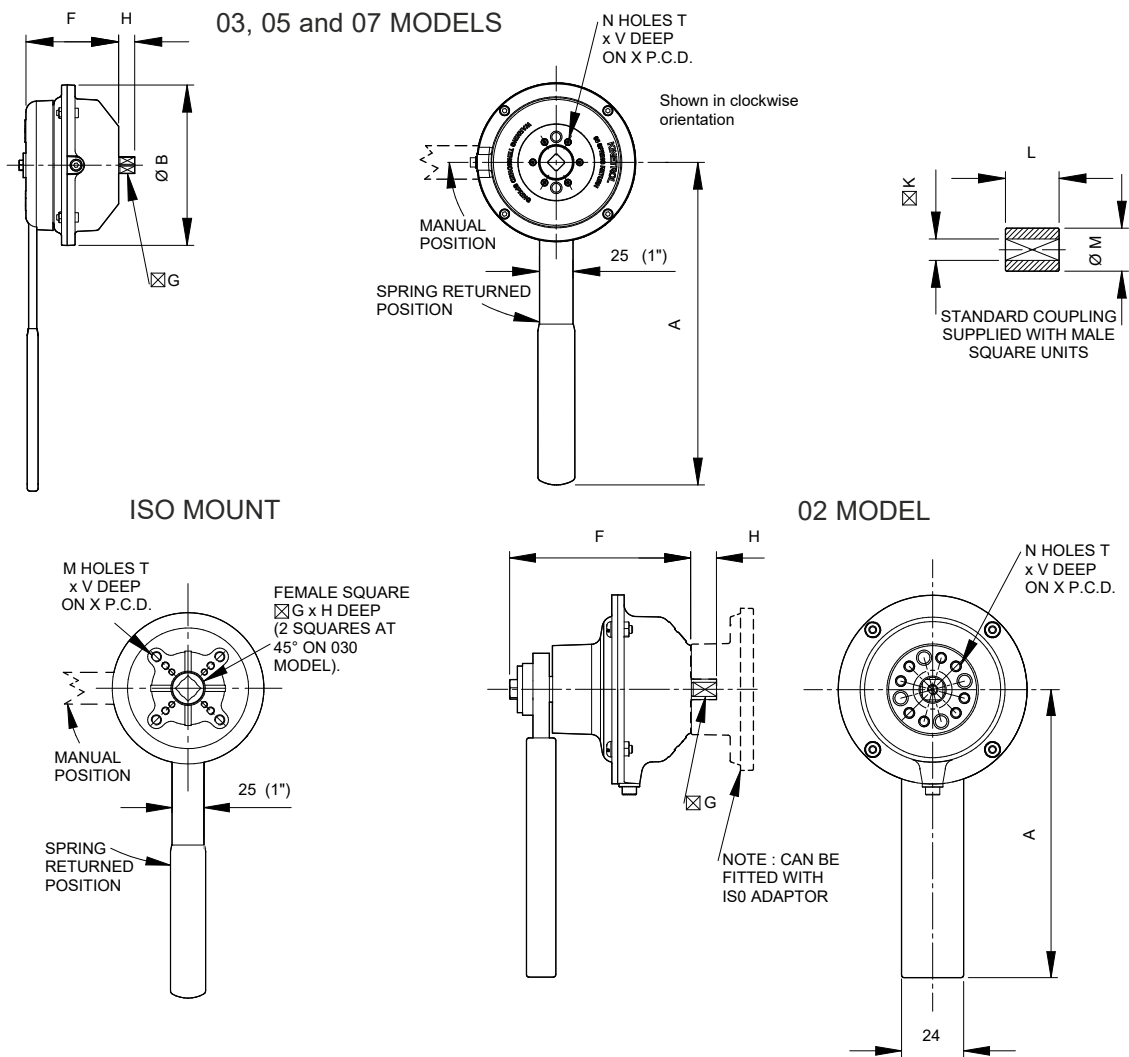

Metric Units

	A	B	C	D	F	G	H†	K	L	M	N	T	V	X	Maximum Torque Nm	Torque Reduction Thro' Stroke Nm
	mm	mm	mm	mm	mm	mm	mm	mm	mm	mm	mm		mm	mm		
024-020-1006	110	73	-	-	70	7.98 7.93	10.0	8.022 8.000	22.0	16.0	4	M4	8.0	25.5	5.1	1.0
034-020-1006	238	108	-	-	62	8.98 8.93	12.0	9.022 9.000	22.0	18.0	4	M5	10.0	31.1	14.0	3.0
054-020-1006	238	118	-	-	68.5	9.525 9.470	13.0	9.58 9.55	25.4	19.0	6	M5	8.0	34.9	24.0	3.5
074-020-1006	360	152	-	-	103	15.98 15.93	20.0	16.027 16.000	40.0	32.0	4	M8	15.0	50.8	45.5	5.8
033F020-1006	238	108	-	-	66	11.0	12.0	-	-	-	4	M5/M6	10/12	36/50	14.0	3.0
033F020-1006/F4	238	108	-	-	66	11.0	12.0	-	-	-	4	M5	10.0	42.0	14.0	3.0
053F020-1006	238	118	-	-	68.5	14.0	16.0	-	-	-	4	M5/M6/M8	10/12/13	36/50/70	24.0	3.5
053S020-1006	238	118	-	-	68.5	*	*	-	-	-	4	M5/M6/M8	10/12/13	36/50/70	24.0	3.5
053F020-1006/F4	238	118	-	-	68.5	14.0	16.0	-	-	-	4	M5	10.0	42.0	24.0	3.5
073F020-1006	360	152	-	-	103	17.0	22.0	-	-	-	4	M6/M8	14	50/70	45.5	5.8
073S020-1006	360	152	-	-	103	*	*	-	-	-	4	M6/M8	14	50/70	45.5	5.8

Weights – Metric	
02 Models	– 0.50 kg
03 Models	– 1.87 kg
05 Models	– 1.87 kg
07 Models	
(Non-ATEX)	– 4.21 kg
(ATEX)	– 5.17 kg

English Units

	A	B	C	D	F	G	H†	K	L	M	N	T	V	X	Maximum Torque lbf.ins	Torque Reduction Thro' Stroke lbf.ins
	inch	inch	inch	inch	inch	inch	inch	inch	inch	inch	inch		inch	inch		
027-020-1006	4.33	2.87	-	-	2.76	0.314 0.312	0.39	0.316 0.315	0.86	0.63	4	8-32	0.310	1.00	45	8.00
037-020-1006	9.37	4.25	-	-	2.44	0.354 0.352	0.47	0.355 0.354	0.86	0.70	4	10-24	0.390	1.22	124	26.55
057-020-1006	9.37	4.64	-	-	2.70	0.375 0.373	0.51	0.377 0.376	1.00	0.75	6	10-24	0.310	1.37	212	31.00
077-020-1006	14.17	5.98	-	-	4.06	0.629 0.627	0.79	0.631 0.630	1.57	1.26	4	¼e-18	0.625	2.00	400	51.00
037F020-1006	9.37	4.25	-	-	2.60	0.43	0.47	-	-	-	4	10-24 / ¼	0.31/0.39	1.42/1.97	124	26.55
037F020-1006/F4	9.37	4.25	-	-	2.60	0.43	0.47	-	-	-	4	10-24	0.390	1.65	124	26.55
057F020-1006	9.37	4.64	-	-	2.70	0.55	0.63	-	-	-	4	10-24 / ¼ / ⅙	0.39/0.47/0.51	1.42/1.97/2.76	212	30.98
057S020-1006	9.37	4.64	-	-	2.70	*	*	-	-	-	4	10-24 / ¼ / ⅙	0.39/0.47/0.51	1.42/1.97/2.76	212	30.98
057F020-1006/F4	9.37	4.64	-	-	2.70	0.55	0.63	-	-	-	4	10-24	0.390	1.65	212	30.98
077F020-1006	14.17	5.98	-	-	4.06	0.669	0.75	-	-	-	4	¼ / ⅙	0.39/0.51	1.97/2.76	400	51.00
077S020-1006	14.17	5.98	-	-	4.06	*	*	-	-	-	4	¼ / ⅙	0.39/0.51	1.97/2.76	400	51.00

Weights – English	
02 Models	– 1.102 lb
03 Models	– 4.123 lb
05 Models	– 4.123 lb
07 Models	
(Non-ATEX)	– 9.281 lb
(ATEX)	– 11.374 lb

* Refer to TD141 for details on serrations and inserts

† Minimum